

MANIGLIA TIPO E53
A NORMA DIN 76051

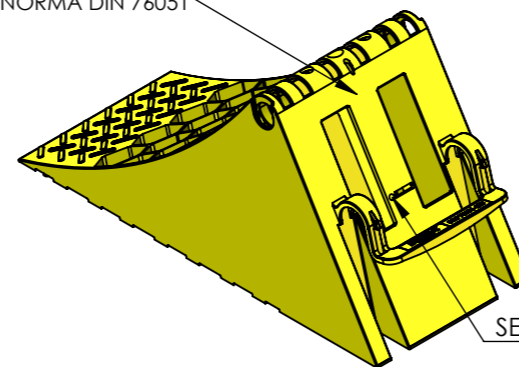

R 2,8
SEDE PER SPINA

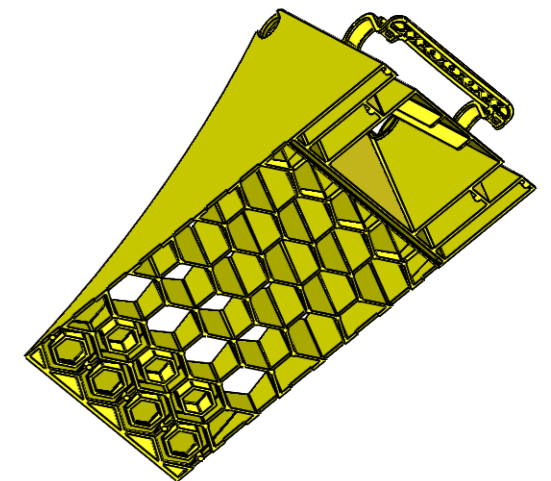
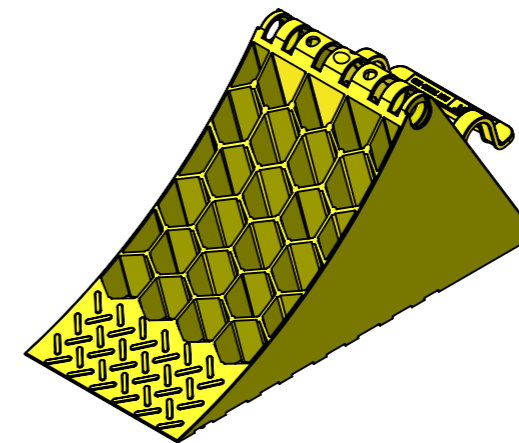

Calzatoia tipologia E53 conforme a DIN 76051 parte 1 e 2
Tipologia impugnatura: forma E
Per quote assenti, fare riferimento al modello 3D

DIN 76051 - Parte 1					
Dimensione Nominale	a +/-5	b +/-5	c +/-5	h +/-5	r +/-5
53	320	150	200	230	560

DIVIETO DI RIPRODUZIONE E DIVULGAZIONE A TERZI SENZA ESPLICITA AUTORIZZAZIONE	Modifica 04	Data	NOME	DATA	SCALA DISEGNO		
			DISEGN.	C.B.	18/09/2019		1:4
	Modifica 03	rif. revisione "CAL001A_07"	Data	VERIF.		DATA DI STAMPA	Quote non tollerate UNI ISO 22768-m
			27/11/2019	APPROV.		27/11/2019	
MATERIALE:					REVISIONE DIS.: 3	A3	
POLIPROPILENE PPC TATREN IM 12 59 (46001) +MASTER GIALLO PER PP (COD.46002)					PESO:		
OMOLOGAZIONE:				COD. COMMERCIALE	N. DISEGNO	N° FOGLIO	
DIN 76051/E53				4460010132	4460010132	1/1	
TITOLO: ZOCCOLO FERMACAMION OMOL.DIN 76051/E53							